

# ESROC

EUROPEAN SLOTRACING ORGANIZATION COMMITTEE

## RULEBOOK 2008

*Revision 23.1.2008*

# TABLE OF CONTENTS

<b>1</b>	<b>ESROC</b>		<b>4</b>	<b>MISCELLANEOUS PROCEDURES</b>		
	1.1	ESROC MEETING	3	4.1	BLACK FLAG	9
	1.2	EUROPEAN CHAMPIONSHIPS RACE ORGANIZER	3	4.2	TRACK CALLS	9
	1.3	JURY	3	4.3	LAP COUNTER	9
	1.4	RACE CLASSES	3	4.4	MARSHALLING	10
	1.5	ESROC PRESIDENT	3	4.5	LANE CHANGE	10
<b>2</b>	<b>GENERAL RULES</b>		4.6	GLUE CONDITIONS	10	
	2.1	GENERAL	4	4.7	ARMATURE PROTEST	11
	2.2	TRACK	4	4.8	G12 LOW COST PROTECTION	11
	2.3	SMOKING	4	<b>5</b>	<b>SPRINT RACE PROCEDURE</b>	
	2.4	ALCOHOL	4	5.1	REGISTRATION	12
	2.5	UNSPORTSMANLIKE CONDUCT	4	5.2	DRIVERS' MEETING	12
	2.6	PROTEST	5	5.3	TECHNICAL SPECIFICATIONS	12
	2.7	WORLD RELATIONS	5	5.4	PARC FERMÉ DURING THE RACE	12
	2.8	WORLD CHAMPIONSHIPS	5	5.5	QUALIFYING	12
	2.9	PRACTICE	5	5.6	THE RACE	13
<b>3</b>	<b>TECHNICAL SPECIFICATIONS</b>		5.7	RACE ORDER	14	
	3.1	SCALE	6	5.8	MOVE-UP SYSTEM	15
	3.2	WIDTH	6	<b>6</b>	<b>OMO RACE PROCEDURE</b>	
	3.3	WHEELS	6	6.1	REGISTRATION	16
	3.4	CLEARANCE	6	6.2	DRIVERS' MEETING	16
	3.5	GUIDE FLAG	6	6.7	TECHNICAL SPECIFICATIONS	16
	3.6	BODY	6	6.5	PARC FERMÉ DURING THE RACE	16
	3.7	CHASSIS SPECIFICATIONS	6	6.3	QUALIFYING	16
	3.8	MOTOR SPECIFICATIONS	7	6.4	THE RACE	16
	3.9	AIR CONTROL DEVICES	7	6.6	WARM UP	16
	3.10	PARTS REPLACEMENT	7	<b>7</b>	<b>TEAM RACE PROCEDURE</b>	
	3.11	CONTROLLER SPECIFICATIONS	7	7.1	GENERAL	17
	3.12	CAR ILLUSTRATION	8	7.2	TEAMS	17
				7.3	TECHNICAL SPECIFICATIONS	17

# 1 ESROC

ESROC is a non-profit organization to promote slotracing in wingcar classes in Europe. ESROC organizes maximal three races per year: The European Championships races in classes G12, (G27-L), OMO, G27 and G7, ESROC Team Race in class G27 and World Championships once every 3 years, in co-operation with USRA and NPRA.

## 1.1 ESROC MEETING

ESROC meeting is the only official decision-making body in ESROC. The rules and regulations are made by the yearly ESROC meeting, taking place at the European Championships race. In the ESROC meeting, every country can have two representatives. Each country has one vote. If a country has no racers taking part in the races, it cannot vote, even if a representative were present (the representative can attend the meeting). Exception: Everything else will be decided at the ESROC meeting, except for the location and time of the EC team race. EC team race location and time will be decided at previous year's EC team race.

The entry fee for each individual EC race will be 30€ in G12, G27-L, OMO, G27 and 35€ in G7 (in team race 60€ / team) or equivalent in national currency.

ESROC gets 20% of the entry fees of all European Championships races from the race organizers, to finance administration and other costs, accepted by the ESROC meeting.

## 1.2 EUROPEAN CHAMPIONSHIPS RACE ORGANIZER

Organizing rights for ESROC European Championships races are granted to the national organization of the selected host country, not to a club. The country can decide where the race will be held. Europe is divided into two regions – north and south. The countries are divided into the regions as follows:

North:

Finland, Norway, Sweden

South:

Austria, Czech rep., Germany, Holland, Italy, Slovakia

The European Championships will rotate alternating between the regions on a yearly basis, unless an unanimous decision is made in the ESROC meeting to deviate from this. Other European countries will be classified in these regions if they should attend.

## 1.3 JURY

In ESROC races, disputes are solved by a jury. The jury consists of one representative from each participating country, plus the chairman. In case of a tie, the chairman's vote will decide.

## 1.4 RACE CLASSES

ESROC classes are OMO, G12 (G27-L), G27 & G7. The winners of these 4 classes are European Champions.

## 1.5 ESROC PRESIDENT

The inning time for ESROC president is 3 years and one person can be ESROC president only 2 periods.

## **2 GENERAL RULES**

### **2.1 GENERAL**

All cars/racers are expected to comply with these guidelines.

- A. All racers are responsible for the legality of their equipment.
- B. Any rule that is in question or being interpreted improperly will be clarified by the ESROC chairman and/ or the jury.
- C. The organizers have to provide prizes at least for the best 8 drivers in each class.
- D. The European Championship races will follow the Sprint race procedure (see chapter 5).
- E. The ESROC Team Race race will follow the Team race procedure (see chapter 6).

### **2.2 TRACK**

For the European Championships, the racetrack has to be equipped with:

- A. An automatic lapcounting system (computer). ,
- B. One monitor has always to be in front of the racers and viewable from the racers' position during the race.
- C. The lanes have to be marked with colors and/ or numbers, the use of colors is preferred.
- D. It is strongly recommended the lap counter be positioned after the banking. Every new track to be used in European Championships (starting 2002) has to comply with this recommendation.
- E. The plugs for controllers have to be marked with Parma colors only. Positive=White, Negative (Brake)=Red, Wiper=Black.
- F. Banana plug (ø 4mm) contacts are mandatory, additional contacts may be used to meet national standards.
- G. The positive pole may be on either side of the slot, but its side has to be mentioned in the invitation.
- H. In all ESROC events, qualifying and racing voltage for all classes will be limited to a maximum of 16.0 volts (class-specific regulations may overrule this). If a power supply unit is used, 13,5 V is suggested for racing. Sufficient battery or power supply capacity is required. The voltages used in qualifying and race have to be mentioned in the invitation. This voltage is to be measured, unloaded without the cars on the track, using accurate digital voltmeters to record the values.

### **2.3 SMOKING**

Smoking is prohibited within the room of the racetrack and connected rooms.

### **2.4 ALCOHOL**

Drinking alcohol within the room of the racetrack and connected rooms is prohibited. Drivers, not able to control their car properly due to excessive consumption of alcoholic beverages, will be excluded from the race.

### **2.5 UNSPORTSMANLIKE CONDUCT**

Unsportsmanlike conduct on the part of a driver or turn marshall will be subject to immediate disqualification at the discretion of the race director. Verbal abuse or profanity will not be tolerated. The race director may first warn drivers, marshalls or pit men if their behaviour is unacceptable. Serious or repeat violations will result in a 5 lap penalty for the first infraction and disqualification for the second. Repeat offenders of any unsportsmanlike conduct guidelines may be prohibited from future ESROC events.

## **2.6 PROTEST**

A competitor may protest another racers equipment by officially informing the race director. Special provisions for armature protest are in the following section.

## **2.7 WORLD RELATIONS**

ESROC and NPRA have decided on the following: The best European racer in ESROC European Championship Gp.7 race will receive a \$500 starting bonus at the NPRA Brazilian Championship (the same year), and the best Brazilian racer at the NPRA Brazilian Championship will receive a similar bonus when entering the ESROC race next year.

## **2.8 WORLD CHAMPIONSHIPS**

A. ESROC, NPRA (Brazil) and USRA (USA) have decided to rotate the World Championships in each continent. Year 2009 the race will be held in Brazil, year 2010 in USA and year 2011 in Europe. The same rotation will be continued.

B. When the race is in Europe, ESROC will be the organizer. The body and ESROC rules will be used. The race classes are beginners class (G12 or G27-L), OMO, G27 and G7. The beginners class and it's rules must be known at least one month before the event. Participations in classes is limited as following: beginners class + G27 or G27 + G7. It isn't possible to enter beginners class + G7. Also not possible to enter beginners class for "Pro racers" (racers who finished last 3 years on podium of Wingcar worlds, European championship or USRA Nats Division.1 ). The classes OMO, G27 an G7 are opened for every one racer.

C. The venue for the next World Championships race in Europe must be decided in the extra ESROC meeting that will be held in the previous ESROC-hosted Worlds (i.e. 3 years in advance). Only European countries' representatives can attend that meeting.

D. The national organization of the country hosting the World Championships under ESROC jurisdiction will be responsible for the running of the race, and can decide where the race will be held.

E. The date for the Worlds must be between and including May 15th–June 15th. It is recommended not to organize the race over Mothers' day weekend or break of the months. At least 2 weeks' space around the event must be kept free of important races.

F. Spray glue conditions will apply during the Gp.27 light race.

G. OMO race will follow the OMO race procedure (see chapter 7). Other races follow the Sprint race procedure (see chapter 5).

H. Trophies for the first 8 drivers + TQ and concours winner in each class.

I. ESROC will receive 10% of the entry fees from Worlds for administration.

## **2.9 PRACTICE**

Sufficient time must be given for the racers to practice on the track in race conditions. Practicing is always free of charge for at least two days prior the first ESROC race, commercial raceways may charge their regular fee before this. It is suggested the track and the race room be kept open until as late in the night as possible. It is suggested a local race type "Semi-Pro" be organized prior the ESROC event (on Wednesday or Thursday the same week) for less experienced racers. The top drivers should not enter this race. This race must be over by 15.00 (3.00 PM) on the Thursday afternoon to allow sufficient (free) practice for the ESROC classes.

### **3 TECHNICAL SPECIFICATIONS**

#### **3.1 SCALE**

The size of scale to which the cars must be built is 1/24th of the actual race car.

#### **3.2 WIDTH**

Maximum width of the car is 82.6 mm. Round head body mounting pins may extend beyond this width. Other type body pins such as glass head or "T"-type are not allowed.

#### **3.3 WHEELS**

All cars must have front and rear wheels (2 each) with rubber tires. Front wheel minimum diameter is 12.7 mm. Front wheels must rotate on their axles.

#### **3.4 CLEARANCE**

The minimum clearance for chassis, gear and motor is 0.8 mm. A driver, being caught with less than 0.8 mm on his car after his qualifying run will have his time disallowed and will be placed in the lowest race. Technical inspections can be made during the race (track call or lane change), and if a car has less than 0.8 mm at any time during the race, the car has to be corrected and checked by the technical inspector during race time before it can return to the track. No penalty is given for too low clearance. The technical inspector has to point out the area that is too low (motor dragging, bent chassis, etc.).

#### **3.5 GUIDE FLAG**

One guide or pickup device per car.

#### **3.6 BODY**

Designs should resemble full size race cars. Manufacturers are urged to maintain scale proportions. Variations are allowed to conform to "state-of-the-art" practices.

A. Paint: All bodies must be fully painted and opaque from above when sitting on the tech block. The sides of the body may remain clear. Bodies should be detailed to resemble full size racecars. All cars must display three numbers of reasonable size and position, 1" minimum. The numbers must be painted (on the underside of body) or as stickers.

B. Interior: All cars must contain a suitable painted, 1/24th scale, detailed driver with helmet, shoulders, arms and steering wheel mounted in the original cockpit position at all times during the race. Plastic and color printed paper drivers permitted.

C. Windshields: Windshields must be clear.

D. Fender wells: Fender wells must be transparent; the front wheels must be visible when viewed from either side of the car.

E. Body openings: The chassis and guide flag must be completely covered by the body and air control when viewed from above, except for the body openings.

#### **3.7 CHASSIS SPECIFICATIONS**

A.No restrictions for G27, OMO & G7.

B.Only steel chassis allowed for G12 & G27-L.

### **3.8 MOTOR SPECIFICATIONS**

A. G7 No restrictions.

B. G27 a. Set up: No restrictions.

b. Armature: Must be tagged with at least the number "27" and approved by USRA. Must be commercially available. Must be wound with a minimum of 38 series wound turns of AWG 27 wire per pole. AWG 27 wire, excluding insulation, is  $\varnothing$  0.358 mm maximum. Armature stack lamination length shall be a minimum of 11.17 mm. (Using calipers with the faces across each end of the pole ) and only the actual lamination material shall be used to determine this figure. This is meant to specifically exclude, as an example, such practices as the insertion of spacer type materials between the laminations, abnormally thick applications of coatings or any methods of artificial compliance with the rule. Any armature that has been purposely altered or tampered with, to make the stack appear longer, so as to attempt to comply with the length rules as listed, shall be declared illegal at the tech inspector's discretion.

C. G27-L (only applicable in World Championships)

As per art. 3.6.B, except for the following limitation: Only one change of motor per stage of race allowed (2 motors for each driver, will be marked before each race – heats, quarters, semis and final). Different marking colours for these have to be used.

D. OMO

As per art. 3.6.A, except for the following limitation: Only one motor per the whole race allowed. The motor will be numbered and sealed. Opening of the motor is not allowed. Replacing the motor by another is not allowed in any condition. Brushes and springs may be replaced.

E. G12

The organizer of the ESROC Championship can prescribe the G12 motor brand/mark.

### **3.9 AIR CONTROL DEVICES**

A. No part may exceed 63.5 mm in height, measured from the racing surface. All air control devices must be clear enough to read normal newspaper print through. Look the chapter 3.12.

B. Side dams: May be a maximum of 63.5 mm in height aft of the rear wheel centreline and continue on a taper making them a maximum of 50.8 mm high at a point 95.3 mm forward of the rear wheel centreline. The same taper must continue ahead of the front wheels. The front edges must be taped and rounded in a manner suitable to avoid injury to race participants and spectators. Side dams must be clear, although suitable decals and markings may be affixed. Look the chapter 3.12.

C. Diaplane: Maximum length is 12.7 mm. Corners must be rounded. Look the chapter 3.12.

D. Rear spoiler: Must be clear, although suitable decals may be affixed.

### **3.10 PARTS REPLACEMENT**

Any component may be replaced during competition except the original chassis and body, unless class rules restrict this further. Any racer found to have switched chassis or body will be disqualified immediately.

### **3.11 CONTROLLER SPECIFICATIONS**

Any controller/choke may be used as long as the controller/ choke uses no batteries or additional power sources to increase voltage or amperage at track braid. Controllers/ chokes are subject to inspection by the ESROC chairman and/ or jury to verify compliance with the rules.

3.12 CAR ILLUSTRATION

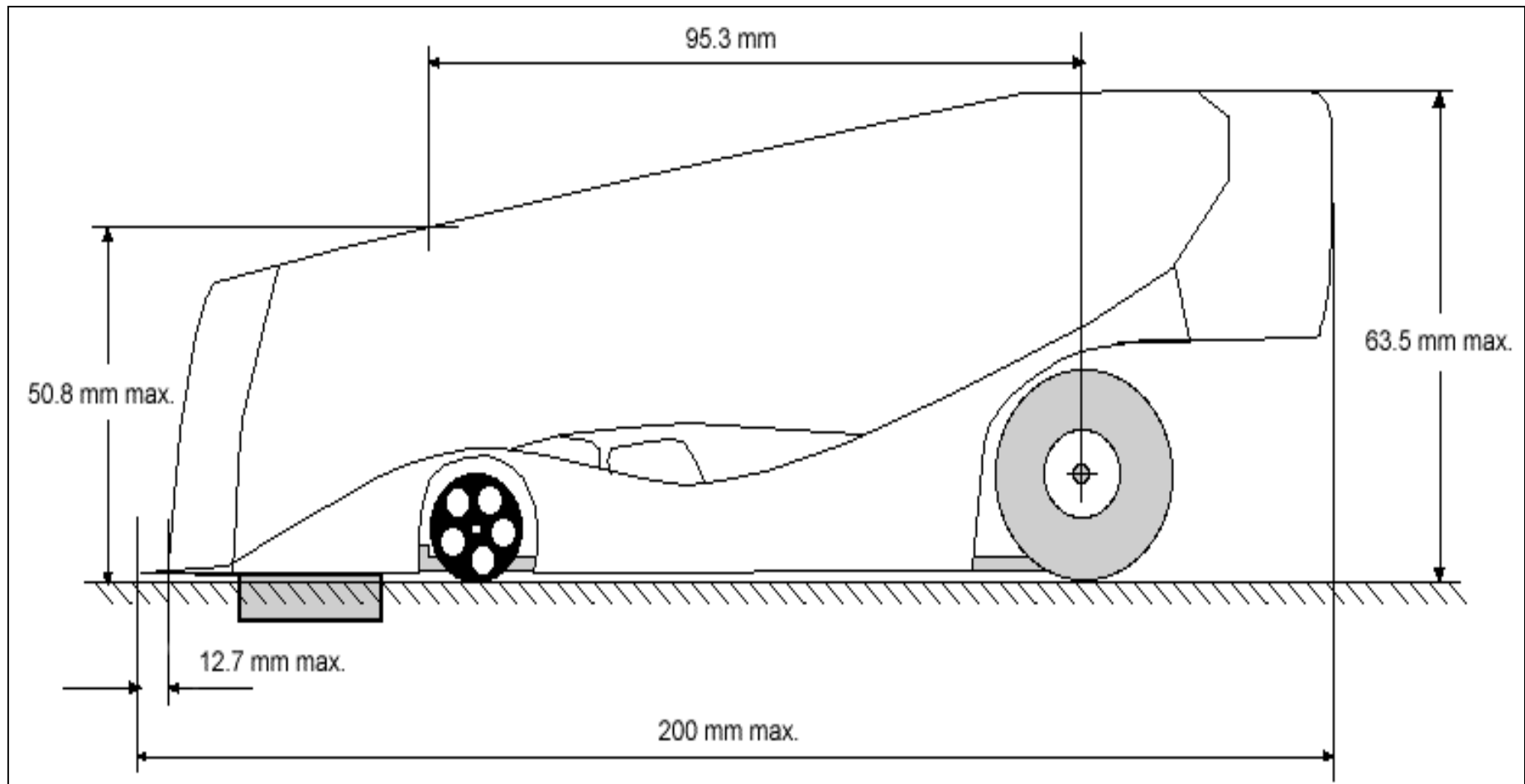



## **4 MISCELLANEOUS PROCEDURES**

### **4.1 BLACK FLAG**

The race director is obliged to black flag any car that is dragging, interfering with other cars or continuously de-slotting due to mechanical problems. Upon being black flagged, the driver must bring the car in for repairs immediately. If the problem is not corrected, the black flag may be enforced again as required.

### **4.2 TRACK CALLS**

The power will only be turned off for extremely unfair or dangerous situations. The following are the only acceptable reasons:

- A. Braid up
- B. Power failure
- C. Debris in slot
- D. An unmarshable car
- E. Deslotted car on the straight
- F. Car in a wrong lane
- G. Lap counter or track equipment failure
- H. Too much glue (10-lap penalty will follow, according to art. 4.6.A)

An illegal track call (none of the above applies) will result in a 2 lap penalty every time. Cars in the pits during a normal track call can be worked on. If the race has to be stopped for a longer time because of track or lap counter failure, the race director calls "no work on cars", so there will be absolutely no work performed on cars on track or in the pits. Doing so will result in a 20 lap penalty. A second infraction will result in disqualification. This includes the pit helpers of the driver.

Too much glue: If a driver has serious problems (too much glue on the track), the driver has the right for a track call to remove glue from the lane. This will result in 10 lap penalty.

### **4.3 LAP COUNTER**

The lap counter will be considered correct unless it can be proved otherwise. The counter should be corrected if necessary (as when a car crosses in the wrong lane). If a major error occurs in the counting process that cannot be corrected, the race director may:

- A. Assign responsible stewards to count laps or verify the counter
- B. Add or subtract mutually acceptable laps as established by race officials and drivers
- C. Restart the segment
- D. Restart the race from the latest possible point

Laps should not be added or subtracted unless the race director is certain the counter is incorrect. For a major error in counting, the steps taken should preserve as much of the race as possible, while remaining as fair as possible to all.

#### 4.4 MARSHALLING

All drivers are expected to marshal the race following their own. Substitute marshalls must be acceptable to the race director and drivers. The marshalling positions (**numbers or colors**) will be marked on the track. The assigned marshalling position of a racer is determined by his/her starting lane in the current stage of the race. All cars will be impounded after all races to ensure fair and proper marshalling responsibilities. Cars will be returned and move-up drivers will be given equal time to prepare for upcoming races.

Good racing is not possible without good marshalls. Every racer is expected to do his/her part both before and after racing if necessary. Failure to fulfill marshalling responsibilities will result in 10 lap penalty and / or disqualification.

#### 4.5 LANE CHANGE

A. Following each lane change, all cars must be returned to the track where they stopped. Drivers have to use lane change cards with their name one it to mark their stopping position. The lane change card is always positioned on the driver's next lane. Putting a car back on the track in an advantageous position will result in a 5 laps penalty. A second infraction will result in disqualification. It is the drivers responsibility to know where the car stopped. When the car is removed from the track during racing, the same rule applies. Corner marshalls should notice the cars stopping in their section and pay close attention to cars near the lap counter section. At the conclusion of each race, cars will be left on the track until the order of finish is positively determined.

B. During a round-robin race, the car(s) with a sit-out turn will be held in the parc fermé or at the race control booth during racing, effective immediately after the end of the previous segment. The sections will be marked and car will be returned to the same location after the sit-out (car will be released immediately after the end of the last sit-out segment).

C. Lane change rotation during an 8-segment race is red (1) ► green (3) ► blue (5) ► purple (7) ► black (8) ► yellow (6) ► orange (4) ► white (2) ► (possible sit-outs) ► red (1). Note: Sit-out places are based on Lane Master lap counting program.

D. When only 4 segments are raced (heats and sub-consis), lane rotation is red (1) ► green (3) ► blue (5) ► a purple (7) ► (possible sit-outs) ► red (1), or black (8) ► yellow (6) ► orange (4) ► white (2) ► (possible sit-outs) ► black (8). Note: Sit-out places are based on Lane Master lap counting program.

#### 4.6 GLUE CONDITIONS

##### A. UNLIMITED GLUE

Glue may be applied to the track. Glue may be removed from the turns with a clean, dry, rag only. Care must be taken to avoid changing conditions on adjacent lanes. All glueing and cleaning of the track braid and straight must be completed before the power comes on. Nothing may be put down or removed during the racing. Doing so will result in a 10 lap penalty. See also chapter 4.2.8. For Gp.27 light only spray glue can be applied to the track by the organizer, racers must not apply any glue (see chapter 2.8.F).

##### B. SPRAY GLUE

Spray glue can be applied to the track by the organizer; racers must not apply any glue. Spray glue conditions can only be applied to G12 and G27-L

##### C. TRACK CLEANING

All braid and the track surface of all straight sections may be cleaned.

##### D. ACCIDENTAL SPILLAGE

If an accidental spillage occurs, the race director may respray the affected area to restore fair racing conditions. PLEASE NOTE: Most cleaning solutions are FLAMMABLE! Care must be taken during their use. Fire extinguishers should be located in the immediate area and other necessary precautions taken to ensure safety.

#### **4.7 ARMATURE PROTEST**

Any competitor may protest another's armature. The competitor must officially inform the race director, at which time the race will be stopped. The protester may "buy a look" by posting a 5 fee. He is then entitled to look at the suspected armature in the car. If not satisfied, he may formally protest which requires posting a fee equal to double the current manufacturers suggested retail price of their respective armature. The "buy a look " fee is transferable. At this time, the armature must then be nondestructively and indelibly marked (suggest unique Dremel marks on the shaft). Extreme care must be exercised to avoid damage to armature balance and delicate components such as ball bearings, motor brushes, etc. An impartial race steward must then be charged with the responsibility of observing and verifying the authenticity of the armature for post racing inspection. The race will then be restarted. Through disassembly and inspection must be conducted immediately upon completion of racing, and must be conducted in a manner assuring accurate technical verification. This can be accomplished by destroying any epoxy or similar binder with extreme heat (a common torch does this nicely). Then dissecting the armature with a Dremel and carefully measuring the wire and counting the turns. The fees will be held by the race director until resolution of the matter, then promptly surrendered to the appropriate party. Likewise, any winnings and/or points will be held pending the outcome of the inspection. " Buy a look " proceeds go to the protested party if not applied to a FORMAL PROTEST.

#### **4.8 G12 LOW COST PROTECTION**

Racer have to sell her / his car after the race if someone wants to buy it. Maximum price is 150 € or equivalent in national currency. If there are more drivers who want to buy it we will draw random the buyer. The reason is to keep costs low in entry class.

## **5 SPRINT RACE PROCEDURE**

### **5.1 REGISTRATION**

All cars shall be inspected and impounded prior to qualifying.

A. No cars will be accepted after announced registration closing time.

B. The chassis should be engraved with the driver's entry number and the initials of the tech inspector. The body should be marked with a spot of non-removable paint.

### **5.2 DRIVERS' MEETING**

It is suggested that a drivers' meeting be held prior to qualifying to discuss race and qualifying procedures, marshalling responsibilities, race, conduct, glue rules, track calls, etc. Drivers with specific questions should ask them at this time

### **5.3 TECHNICAL SPECIFICATIONS**

Chapter 3 applies. In G27-L also 3.8.C applies.

### **5.4 PARC FERMÉ THE DURING RACE**

All cars that will start in the next stage (heats, quarterfinals, etc.) of the race, will be impounded in parc fermé before the start of the first race. The cars will be given to the drivers 5 minutes before the start of their race. The cars will be returned to the parc fermé after the end of the race. An equal and sufficient time (at least 30 minutes) will be given to all racers to repair their cars between the stages. No cars in parc fermé during a night.

### **5.5 QUALIFYING**

A. ORDER:

Determined randomly, such as drawing from a hat.

B. FORMAT:

a. A two minute run is allowed to establish the fastest single timed lap. Back up times will be recorded to alleviate tie breakers.

b. The first qualifier will receive one extra minute to break in the qualifying lane (with a spare car, if necessary).

c. Byes: A racer may take a bye for any reason (may abort initial qualifying attempt and re-attempt during the bye round). Thirty seconds will be deducted from the racer's remaining time as a penalty for using a bye. Cars will be technically inspected prior to the bye round. Times made during the initial attempt and the bye round will count. Byes will be run (racers' remaining time less thirty seconds deduction) at the end of qualifying in the same order as the original round.

d. No shows: Any registered racer not present to qualify when called will be given an automatic bye. Any racer unavailable for the bye will stand by his/ her previous best, or if no times are recorded, will be placed in the lowest level of consolation races.

e. After first qualifying attempt cars go back to parc fermé. When all drivers have finished their first qualifying attempt cars can be collected. After 15 minutes, cars have to be back in parc fermé. A driver not handing back his car in time can not run his bye round. After bye run, cars go back to parc fermé, and can be collected after the end of qualifying.

## 5.6 THE RACE

Modified Australian race format:

- A. The race consists of a series of heats, quarterfinals, semifinals and a final, depending on the number of entries.
- B. All races before and including heats will be contested over 4 lanes, running on either the red set, i.e. red, green, blue and purple lanes (1,3,5 & 7) or the black set, i.e. black, yellow, orange and white lanes (8,6,4 & 2).
- C. All races from and including quarterfinals to final will be contested over 8 lanes.
- D. All races will be on a move-up basis, i.e. 4 fastest from each race will move up, unless stated otherwise.
- E. From the qualifying, racers will be placed in their respective races using snake system.
- F. Depending on the number of entries, the following applies:
  - a. 2-8 racers: Final only.
  - b. 9-16 racers: Two semis and a final. Four fastest from each semi move up.
  - c. 17 racers: All racers into three quarters. Four fastest from each quarter plus four best by laps move up to semis. Two semis (four fastest from each move up) and a final.
  - d. 18-19 racers: All racers into three quarters. Five fastest from each quarter plus the best by laps move up to semis. Two semis (four fastest from each move up) and a final.
  - e. 20-32 racers: All racers into four quarters. Four fastest from each quarter move up to semis. Two semis (four fastest from each move up) and a final.
  - f. 33 racers: Top 25 from qualifying into quarters. Last 8 racers to one heat (top 7 move up), four quarters, two semis and a final.
  - g. 34 racers: Top 26 from qualifying into quarters. Last 8 racers to one heat (top 6 move up), four quarters, two semis and a final.
  - h. 35 racers: Top 27 from qualifying into quarters. Last 8 racers to one heat (top 5 move up), four quarters, two semis and a final.
  - i. 36 racers: Top 28 from qualifying into quarters. Last 8 racers to one heat (top 4 move up), four quarters, two semis and a final.
  - j. 37-38 racers: Top 22 from qualifying into quarters. Last racers to two heats (top 5 from each move up), four quarters, two semis and a final.
  - k. 39-48 racers: Top 16 from qualifying into quarters. Last racers to four heats (top 4 from each move up), four quarters, two semis and a final.

Lane choice will first be determined by the qualifying results, and then by lap total and finishing position. The picking order between the heats, quarters and semis will be determined by the lap totals of their winners (i.e. winner of the fastest quarter will have the first pick, then the winner with 2nd most laps, then the winner with 3rd most laps, then the winner with least laps, then the 2nd finisher in the fastest quarter, and so on). The lucky losers (best by laps) will pick their lanes last.

**5.7 RACE ORDER**

Races always start with the lowest group. Racers can always choose the lane they want to start on.

**ORDER OF RUNNING:**

Heat/sub-consis	D-C-B-A
Quarter	D-C-B-A
Semi	B - A
Final	A

**DRIVING & LANE CHANGE TIME**

Heat/sub-consis	G12 or G27-L		OMO		G27		G7	
Heat/sub-consis	4 x 2 min.	3 min.			4 x 2 min.	3 min.	4 x 2 min.	3 min.
Quarterfinal	8 x 2 min.	3 min.			8 x 2 min.	3 min.	8 x 2 min.	3 min.
Semifinal	8 x 3 min.	3 min.			8 x 3 min.	3 min.	8 x 3 min.	3 min.
Final	8 x 4 min.	4 min.	8 x 4 min.	3 min.	8 x 4 min.	4 min.	8 x 5 min.	4 min.

## 5.8 MOVE-UP SYSTEM

### Final

1st in faster semi  
 1st in slower semi  
 2nd in faster semi  
 2nd in slower semi  
 3rd in faster semi  
 3rd in slower semi  
 4th in faster semi  
 4th in slower semi

If there are 2-8 racers, lane choice in final by qualifying result.

### Semifinal A

1st in faster quarter A or B (or Qual #1)  
 1st in slower quarter A or B (or Qual #4)  
 2nd in faster quarter A or B (or Qual #5)  
 2nd in slower quarter A or B (or Qual #8)  
 3rd in faster quarter A or B (or Qual #9)  
 3rd in slower quarter A or B (or Qual #12)  
 4th in faster quarter A or B (or Qual #13)  
 4th in slower quarter A or B (or Qual #16)

### Semifinal B

1st in faster quarter C or D (or Qual #2)  
 1st in slower quarter C or D (or Qual #3)  
 2nd in faster quarter C or D (or Qual #6)  
 2nd in slower quarter C or D (or Qual #7)  
 3rd in faster quarter C or D (or Qual #10)  
 3rd in slower quarter C or D (or Qual #11)  
 4th in faster quarter C or D (or Qual #14)  
 4th in slower quarter C or D (or Qual #15)

When 17-19 racers, the racers from the three quarters are classified in the following fashion: 1st in fastest quarter (Semi A), 1st in 2nd fastest quarter (Semi B), 1st in slowest quarter (Semi B), 2nd in the fastest quarter (Semi A), etc., placing the lucky losers last on the list according to their laps.

### Quarterfinal A

1st Qualifier  
 8th Qualifier  
 9th Qualifier  
 16th Qualifier  
 17th Qualifier  
 24th Qualifier  
 25th Qualifier  
 32nd Qualifier

### Quarterfinal B

2nd Qualifier  
 7th Qualifier  
 10th Qualifier  
 15th Qualifier  
 18th Qualifier  
 23rd Qualifier  
 26th Qualifier  
 31st Qualifier

### Quarterfinal C

3rd Qualifier  
 6th Qualifier  
 11th Qualifier  
 14th Qualifier  
 19th Qualifier  
 22nd Qualifier  
 27nd Qualifier  
 30rd Qualifier

### Quarterfinal D

4th Qualifier  
 5th Qualifier  
 12th Qualifier  
 13th Qualifier  
 20th Qualifier  
 21st Qualifier  
 28th Qualifier  
 29th Qualifier

When 33-36 racers: Winner of heats goes to quarter B, second to quarter C and so on, when 37-38 racers: Winner of faster heat goes to quarter B, winner of slower heat to quarter A and so on and when 39-48 racers: Winner of heat A goes to quarter A, winner of heat B to quarter B and so on.

Faster semifinal, faster quarterfinal = the semifinal / quarterfinal whose winner had most laps.

## **6 OMO RACE PROCEDURE**

### **6.1 REGISTRATION**

Chapters 5.1.A and 5.1.B applies.

### **6.2 DRIVERS' MEETING**

Chapter 5.2. applies.

### **6.3 TECHNICAL SPECIFICATIONS**

Chapter 3.6.D applies. Otherwise as in chapter 3.

### **6.4 PARC FERMÉ DURING THE RACE**

All cars go to Parc fermé after technical inspection. Before qualifying give organizer cars on the track. Driver can prepare her / his car before her/his qualifying session. After qualifying go cars back to Parc fermé.

For the race organizer put the racing cars on starting line. After the heat of each group organizer collect cars and give them back to Parc fermé.

### **6.5 QUALIFYING**

#### **A. ORDER:**

Determined randomly, such as drawing from a hat.

#### **B. FORMAT:**

- a. A 30-second run is allowed to establish the maximum number of laps and sections. Qualifying will be run on race voltage (no raised qualifying voltage allowed).
- b. The first qualifier will receive one extra minute to break in the qualifying lane (with a spare car, if necessary).
- c. No byes.
- d. No shows: Any registered racer not present to qualify when called will be classified last and placed in the lowest level of consolation races.
- e. After the qualifying attempt cars go back to parc fermé. There is no reparation of cars between qualifying and the next stage of race.

### **6.6 THE RACE**

The race consist only of final groups 8 x 4 minutes. The number of registrated drivers will be devided in to equal member groups. If not possible, most drivers go to the best groups. The worst group start the race. The winner is the driver with most laps and segments. The winner of the race can come from every possible final.

### **6.7 WARM UP**

No Warm up in the OMO race.



## **7 TEAM RACE PROCEDURE**

### **7.1 GENERAL**

The race consists of qualifying and heats. The qualifying is done by one driver/ team, for 1 minute. The qualifying is based on laps and segments. Duration of race about 4 hours (2 hours on Saturday and 2 hours on Sunday) divided in 16 heats of 15 minutes, 5 minutes lane change.

### **7.2 TEAMS**

A. 2-4 drivers/ team.

B. Each team has a marshal.

C. Each driver has to make the following quantity of heats (no driver change during drive time):

a. team with 2 drivers - 8 heats/ driver

b. team with 3 drivers - minimum 5 heats/ driver

c. team with 4 drivers - 4 heats/ driver

With 9-11 teams competing, there will be sit-outs, i.e. after the last lane the car has to be handed to the race direction immediately and will be handed back before the next heat. With 12 - 16 teams there will be 2 separate groups. If the teams are divided into two groups, the first group to run is the one with the lower qualified teams. The heats will alternate, i.e. the group with the lower qualified teams will run one heat first, then the group with best qualified teams will run one heat, and so on. For Sunday, for the beginning of heat 9, the teams are rearranged into the groups based on the Saturday results. During lane change cars may not be touched. Repairs only during race time. During race time, one team-mate of each team in that group must marshal.

### **7.3 TECHNICAL SPECIFICATIONS**

Group 27. Chapter 3 applies.

Exception: 2 bodies are allowed (same colour, same type). The reserve body must stay in Parc Fermé. It can be taken from there for the change, and then the other body must be replaced in parc fermé.